

# Educational Interoperability

A visual language

*Version November 2024*

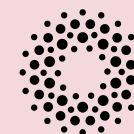

**Npuls**

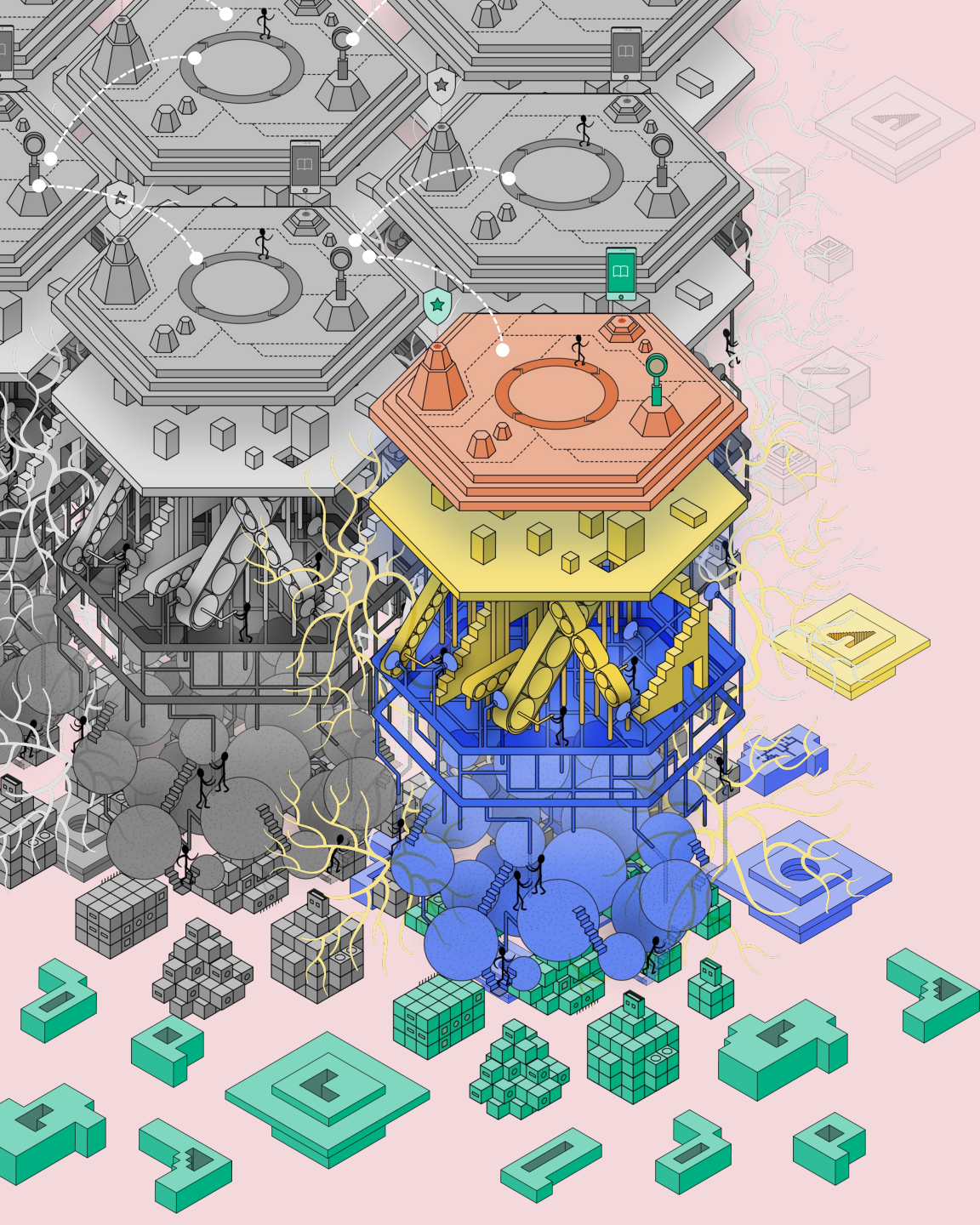

# CC BY-NC-SA 4.0 DEED

Attribution-NonCommercial-ShareAlike  
4.0 International

These slides can be used, for example, in your presentations. When you use the images, please add this credit to them  
(for example on your slides):

*Bakker, N., Janse, D., Renders, E.A., (2024) Educational interoperability. Utrecht: Npuls. [www.interopvisual.eu](http://www.interopvisual.eu)*

Design: Dirma Janse  
Content: Team Educational Innovation at SURF,  
powered by Npuls

For questions of more info, contact us at  
[interoperability@surf.nl](mailto:interoperability@surf.nl).

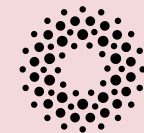

**Npuls**

# The ecosystem overview

- A planetary ecosystem is a biological community of interacting organisms and their physical environment
- The education sector functions within a dynamic ecosystem.
- Organismes: educational institutions, standardisation bodies, governmental organisations, and service providers (such as educational technology companies)
- Environment: all interacting within an environment shaped by economic, social, and technological factors.

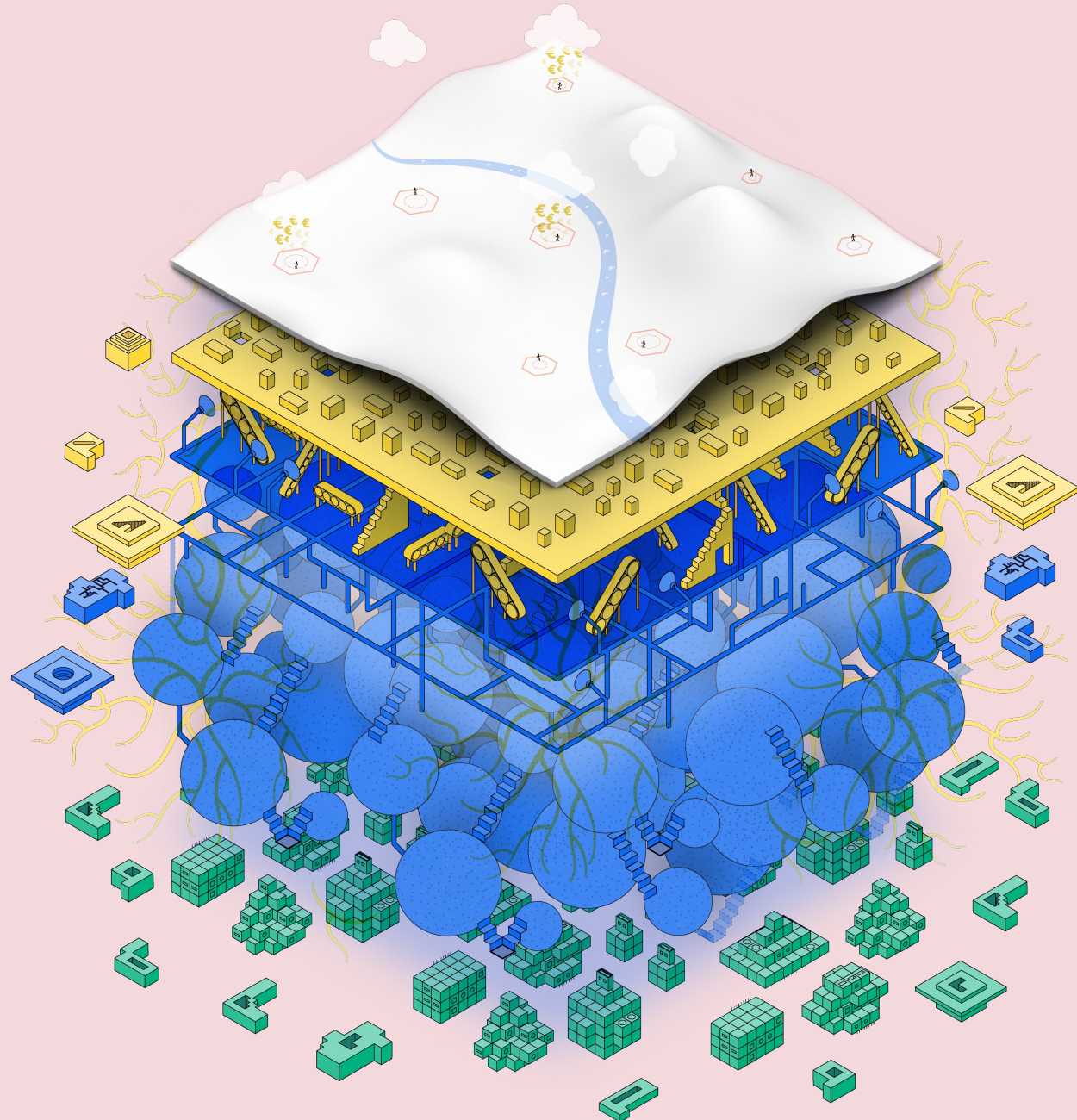

# The institution

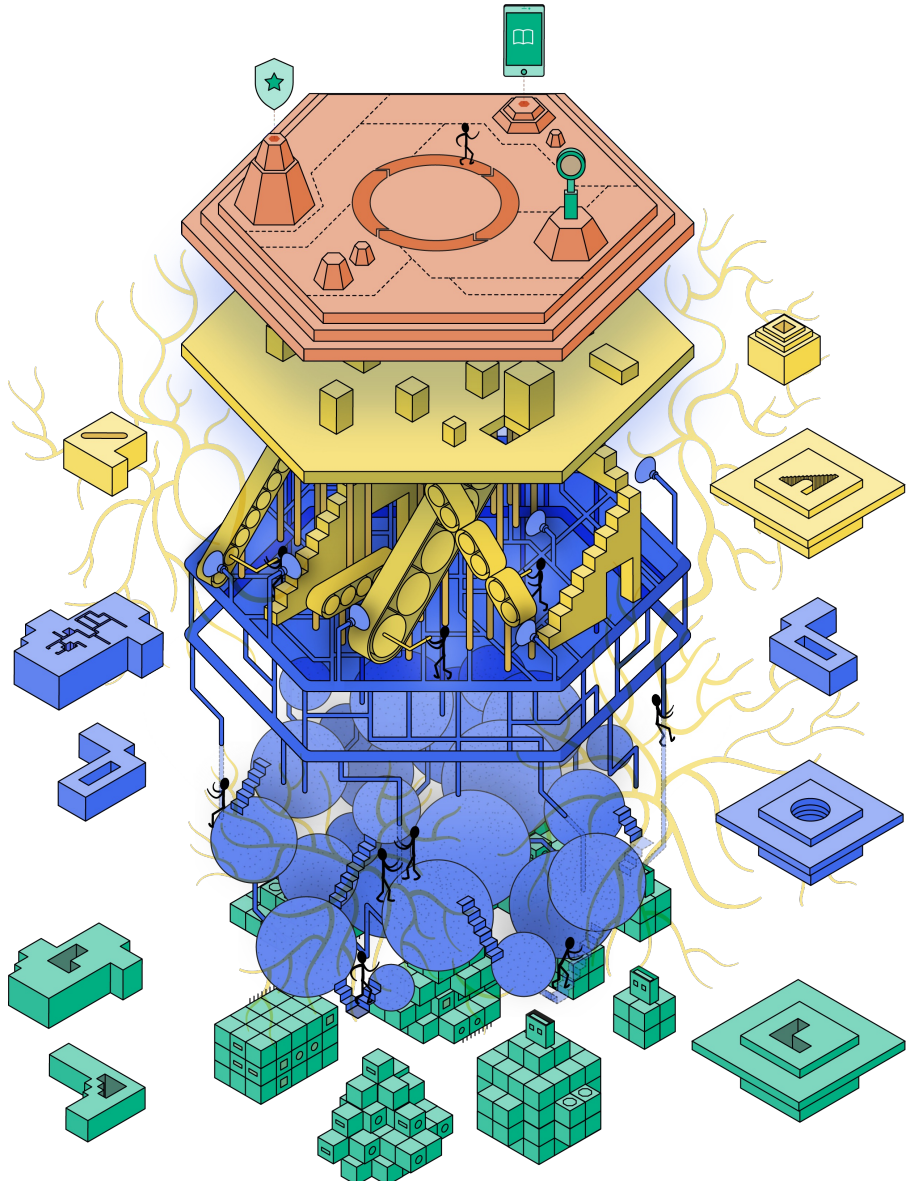
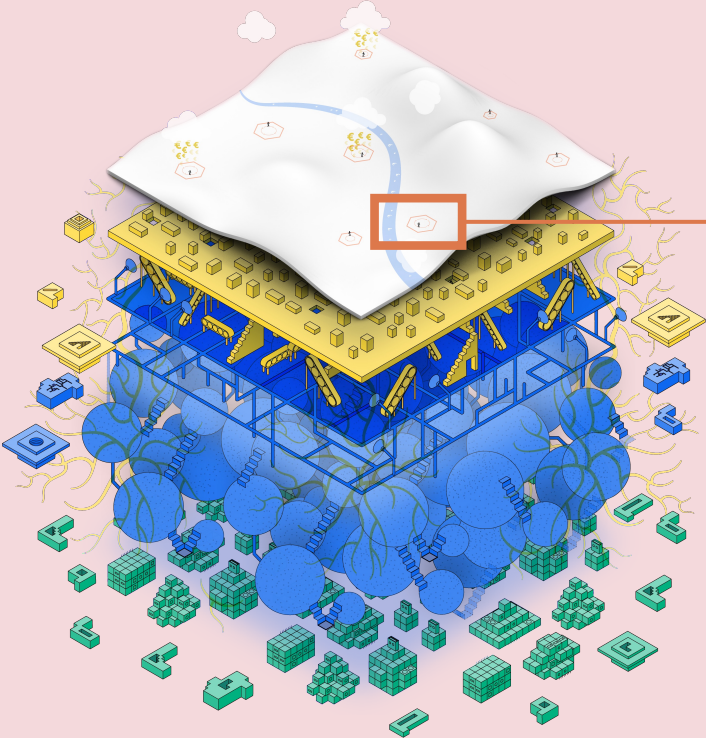

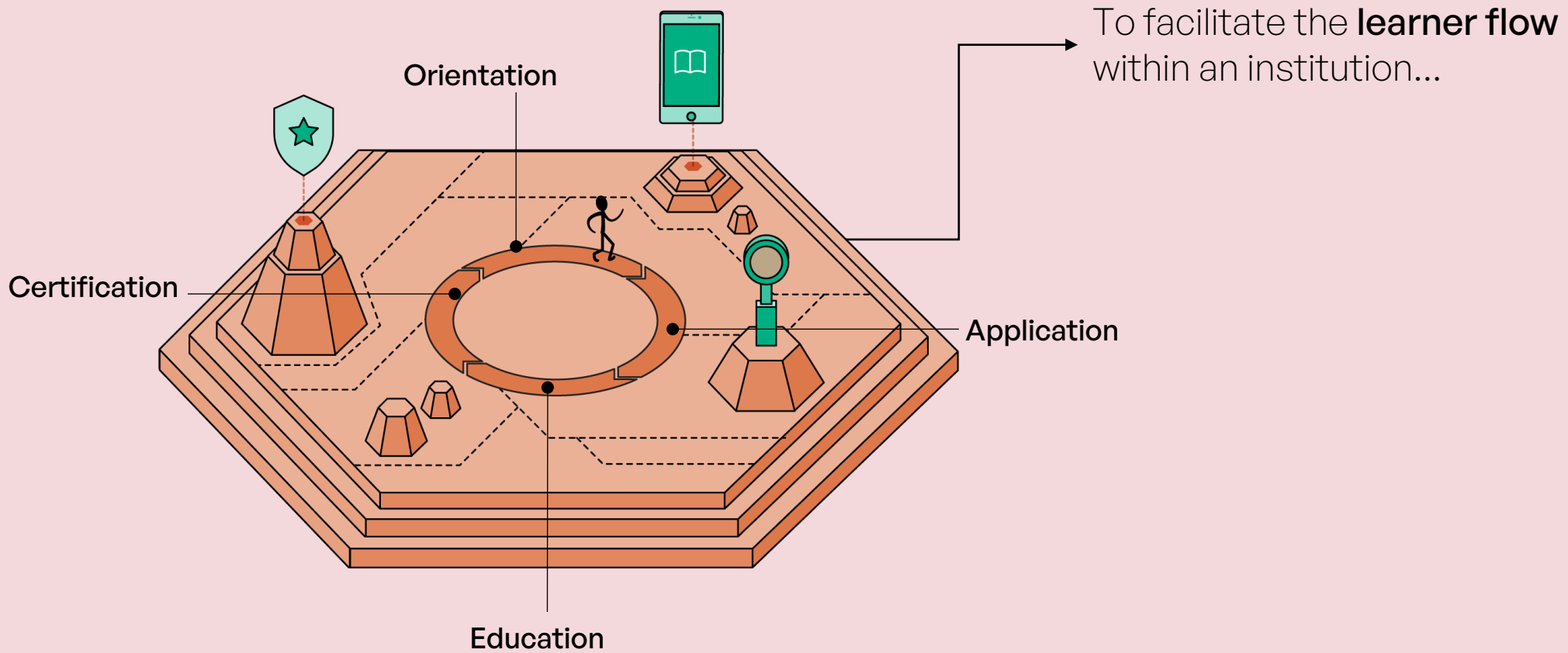

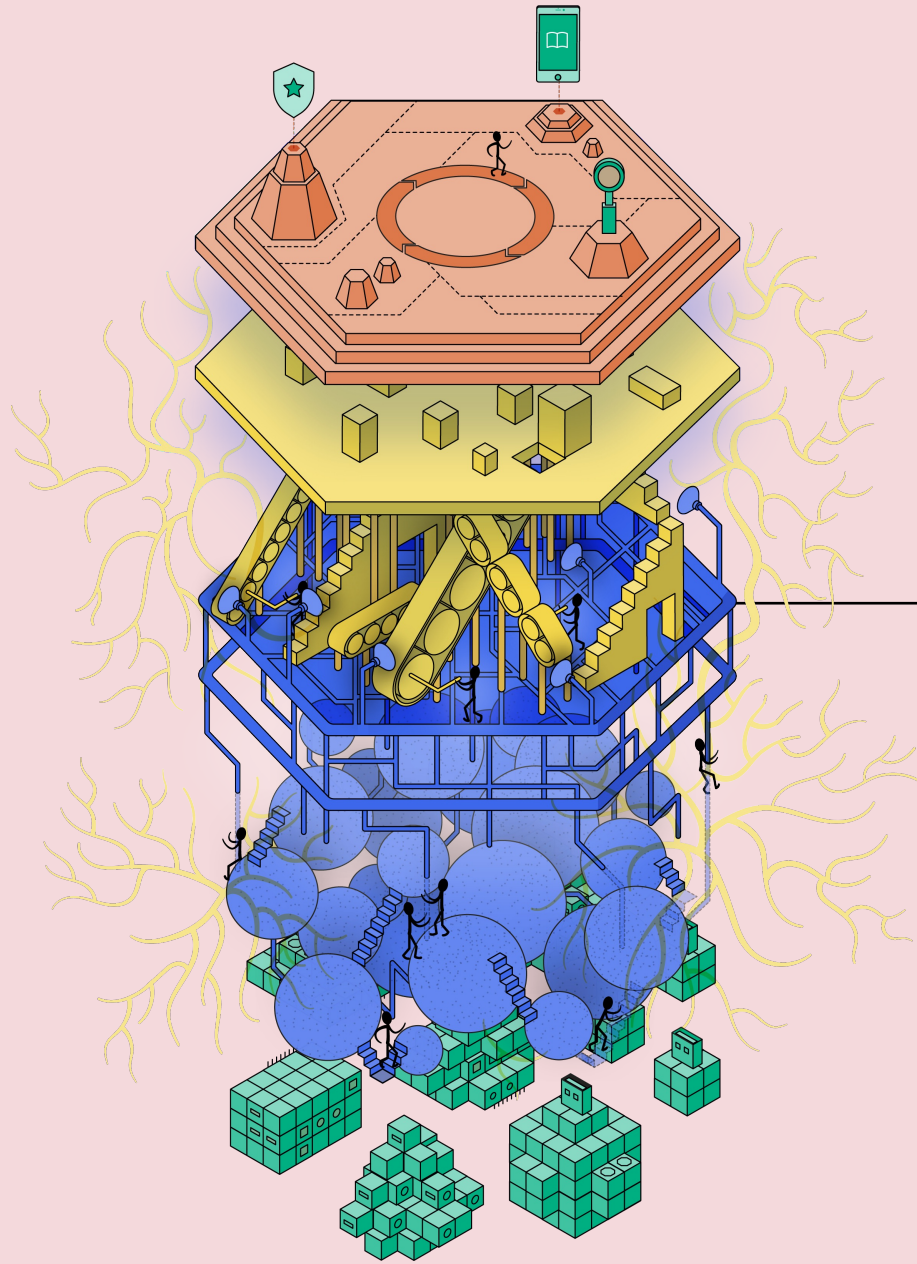

... a whole *invisible*  
**ecosystem** is needed.  
This ecosystem consists of  
**four layers.**

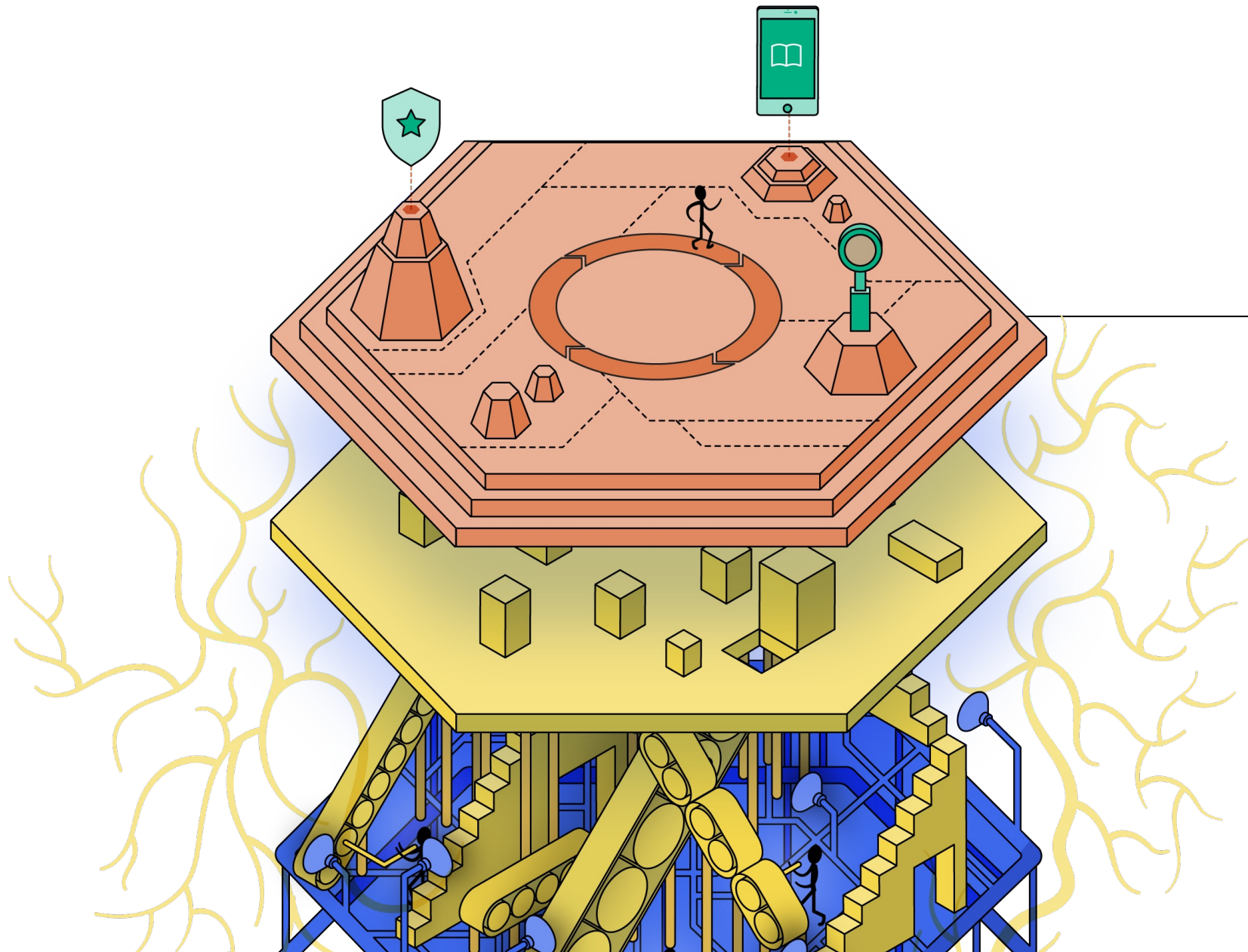

## Users & Services

The top layer outlines the objectives of the users. Learner, teacher and staff want their needs to be fulfilled.

*Examples:*

- *The learner wants an education path that fits/satisfies their needs.*
- *The teacher can create courses that fit the learner's need and meet desired educational outcomes.*

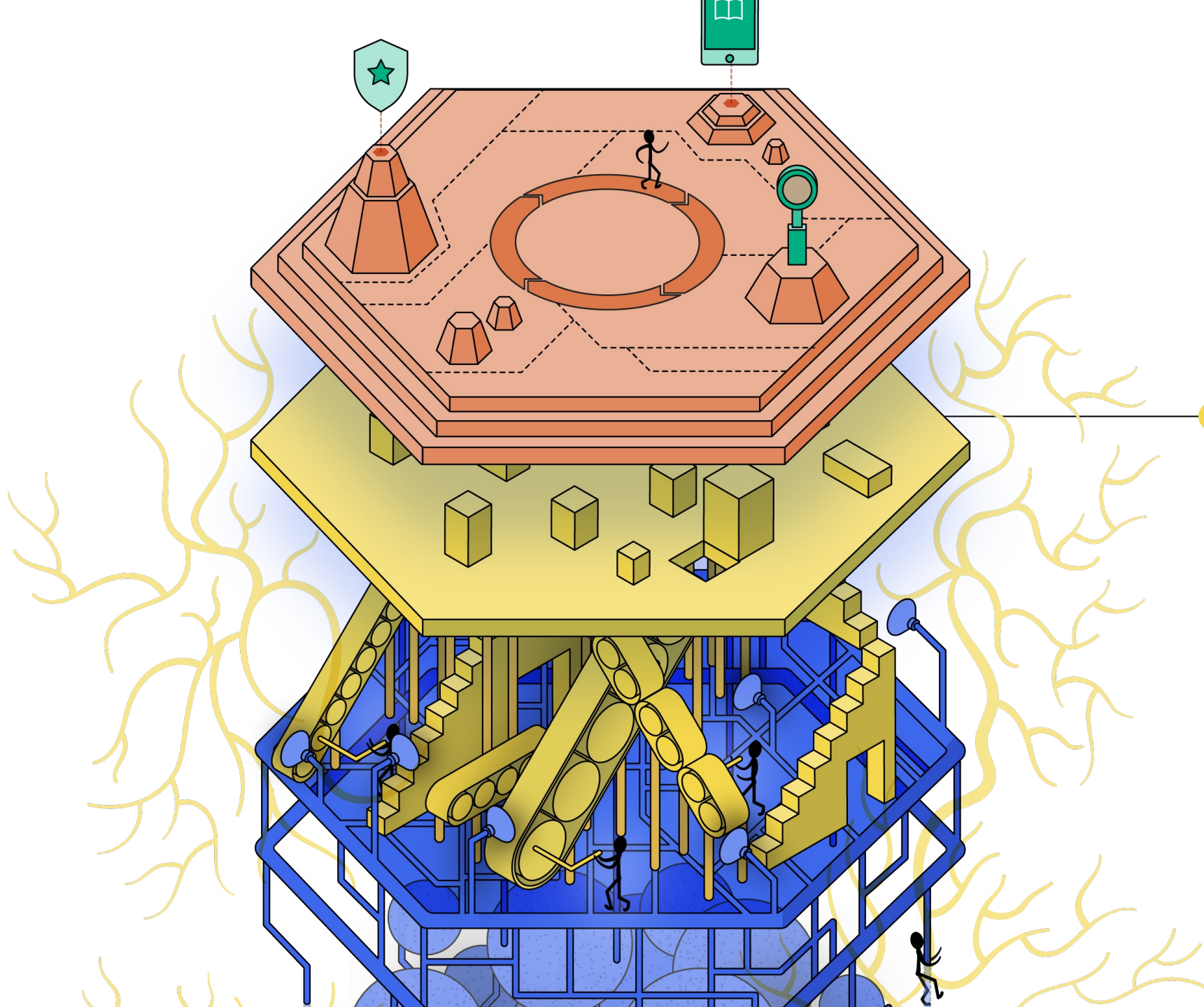

## Organisation & Processes

Next, the 'business' layer is about designing and managing the education operations, to meet the goals set in the top layer. For example curriculum development, exam organisation or scheduling.

*Examples:*

- *The program director designs a program in collaboration with the teachers' team.*
- *The CIO, in collaboration with educational experts and IT teams, oversees the procurement and configuration of the most suitable LMS.*



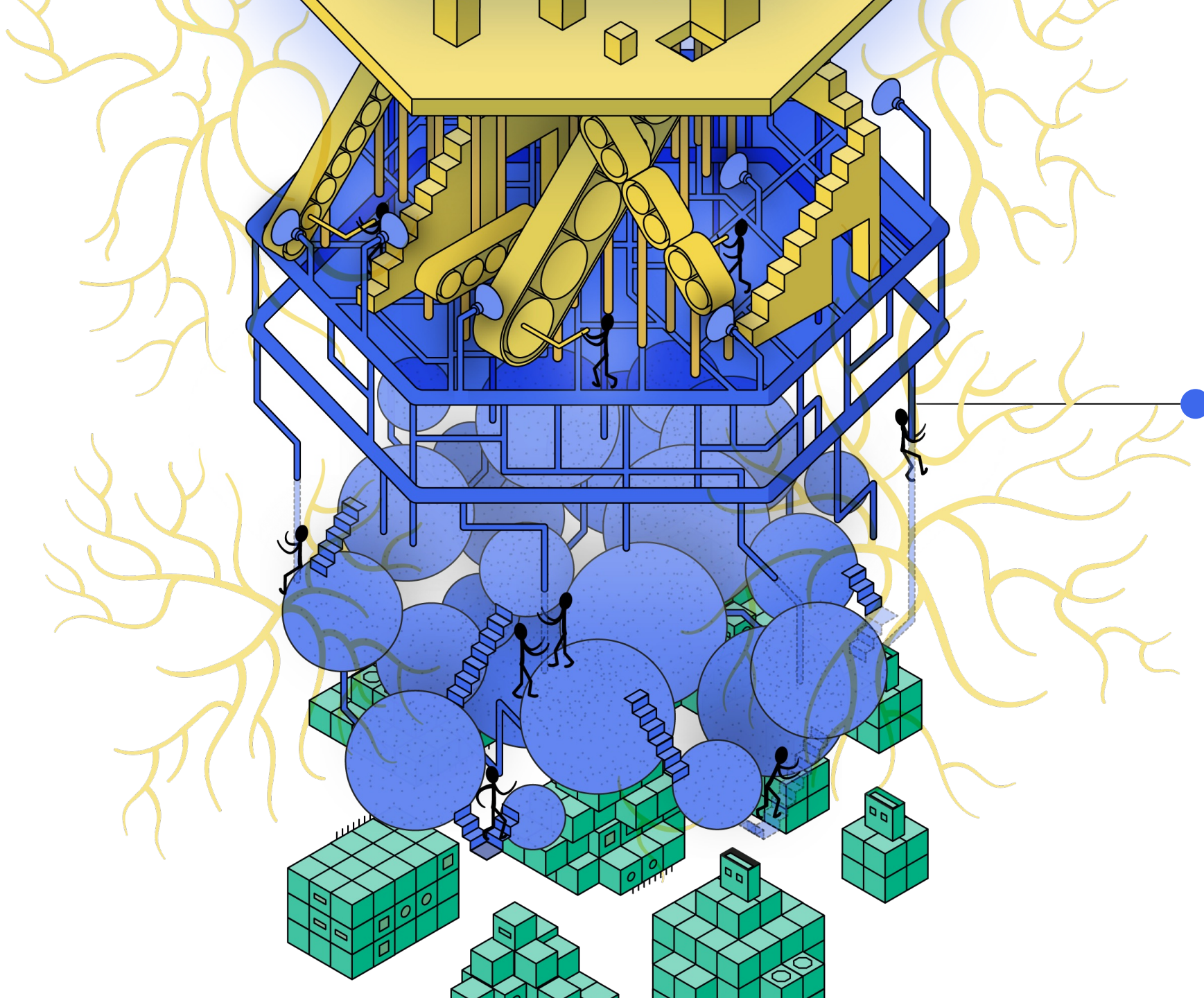

## Applications & Information

This layer is about what IT should do.

*Examples:*

- *Functional application managers find solutions that meet user needs. They define how to execute these within an application, following business processes.*
- *The International Exchange Officer can access student data for current exchanges. This helps them keep information up-to-date to manage and support international programs well.*

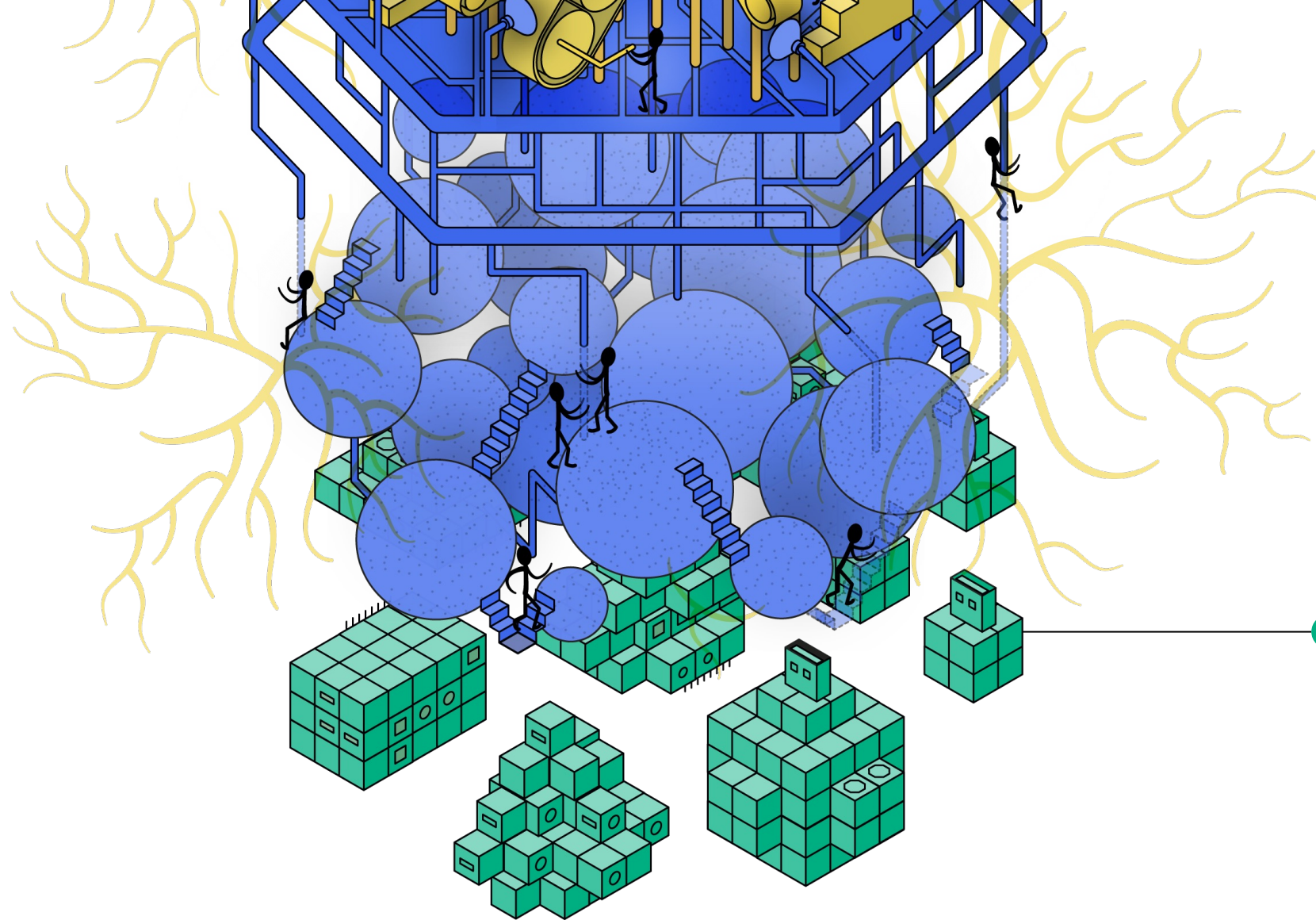

## Technology

While this layer is about how IT is managed. IT staff handle identities, access and databases.

*Examples:*

- *IT managers and NRENs like SURF ensure secure connections and data exchanges between institutions.*
- *Integration specialists ensure standards for information exchange and storage are agreed upon and implemented (e.g. APIs).*

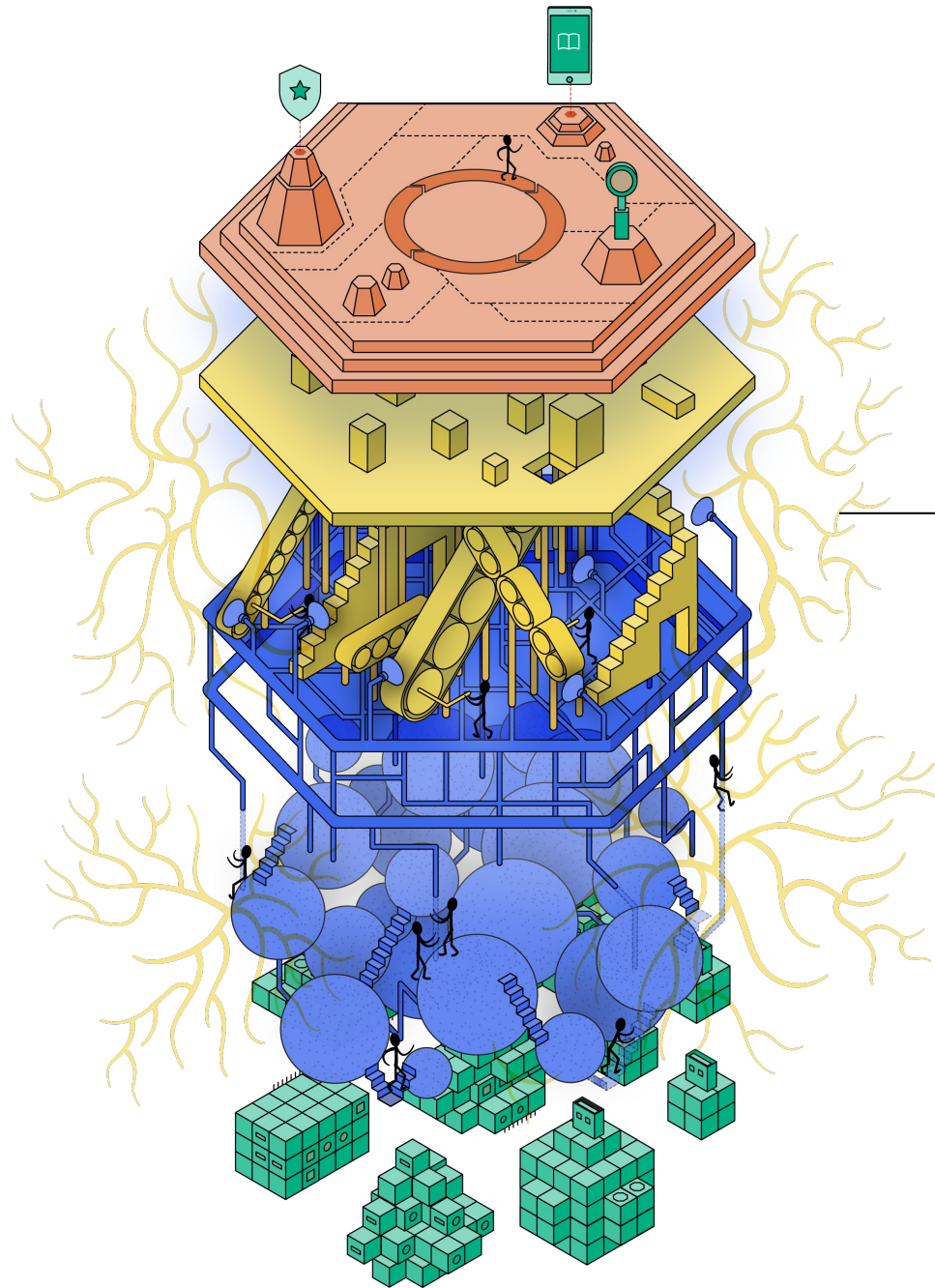

## Policy & Legislation

● Legislation is produced and implemented on different scopes:

*For example, GDPR is European legislation that has a global impact. It is translated into national legislation and fuels the local privacy policy of an institution.*

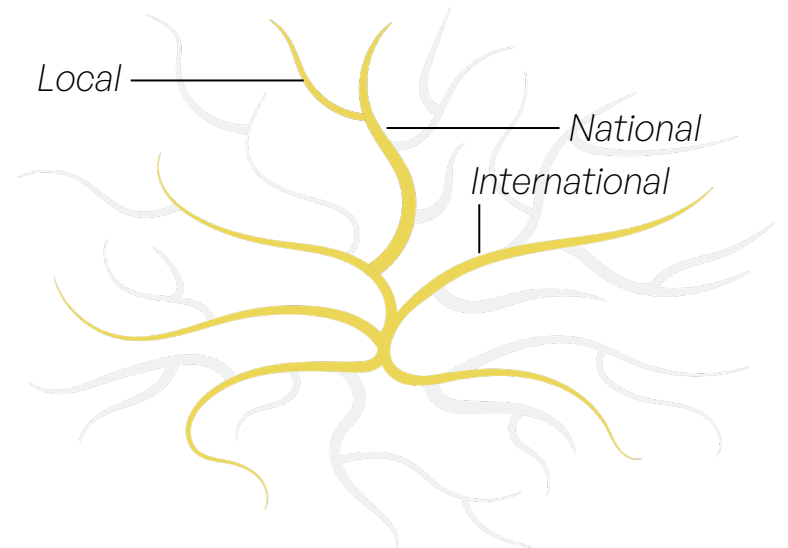

# Policy & Legislation

Legislation can:

Support the ecosystem,

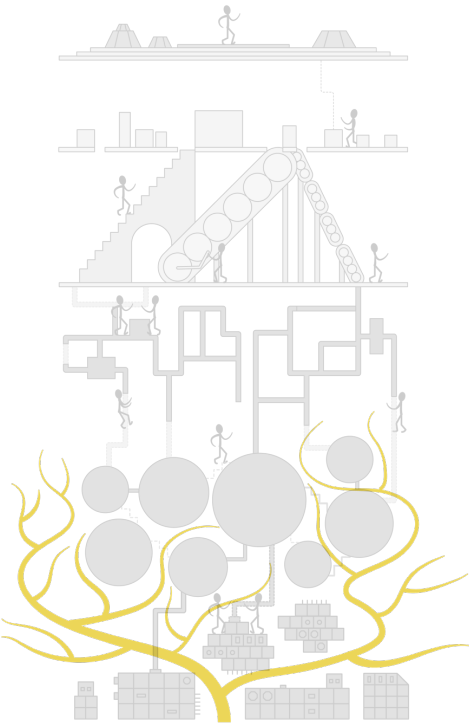

not support it,

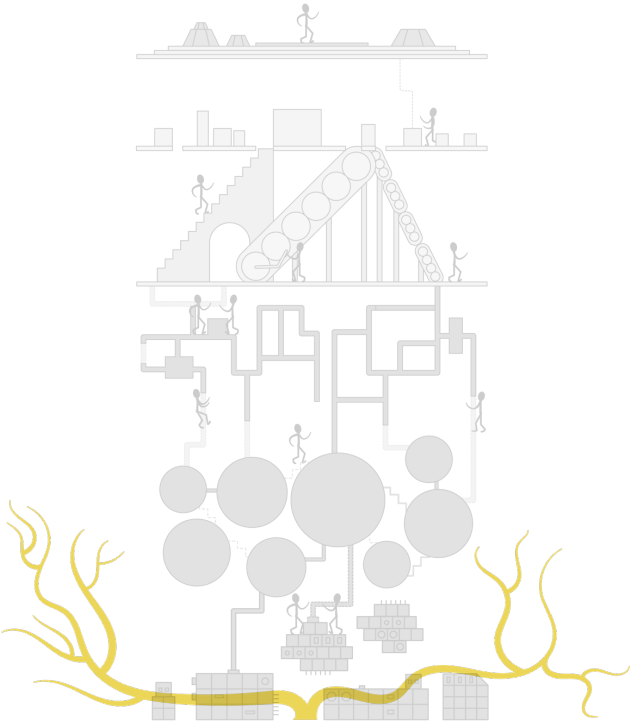

it may even undermine it.

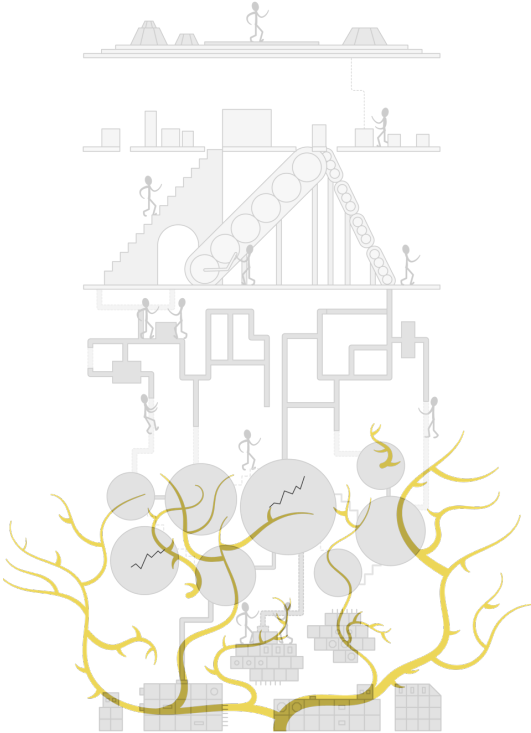

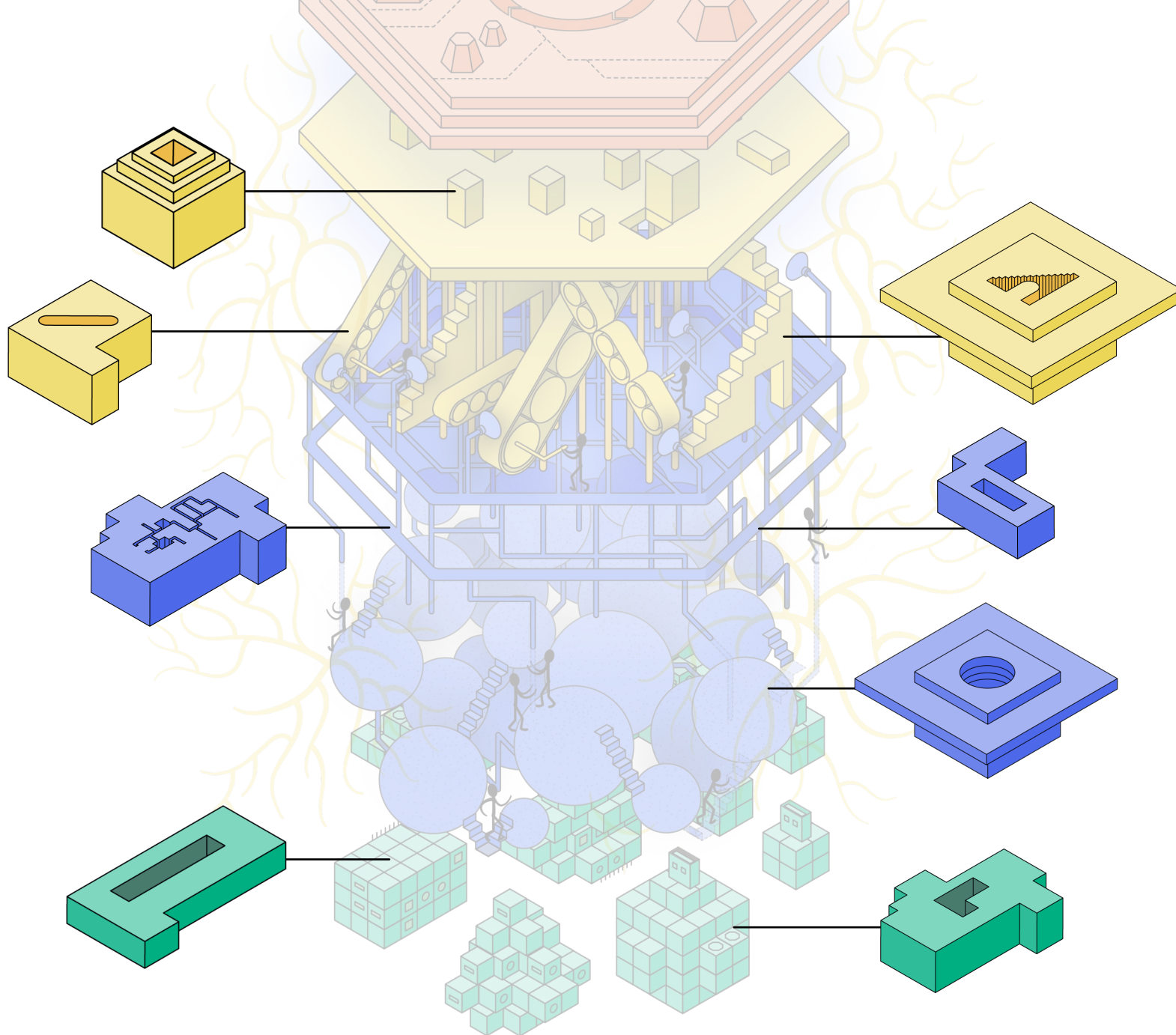

## Standards

A standard is an agreement on information or a process, which can have various perspectives for consistent digitalisation and data exchange:

*Examples:*

- *Semantic standards: defining terms like 'diploma' or 'teacher'.*
- *Metadata standards: enabling data to be placed in the right context.*
- *Standard processes, such as conducting a privacy impact assessment when making decisions about the collection and use of personal data.*
- *Technical standards, such as IPv6 for network communication.*

# What do we mean with a standard?

- We don't mean 'broad definition': Agreement on how to work on information security (ISO 27001) is broad and mostly affects the business layer
- The green layer is about 'technology' and 'data standards'
- Standards are part of the IT vision, not based on it. And the IT vision is an integral part of the organisation's vision and goals.
- An established norm or requirement about technical systems and protocols that ensure compatibility, interoperability, and quality across different digital platforms, software, and devices.

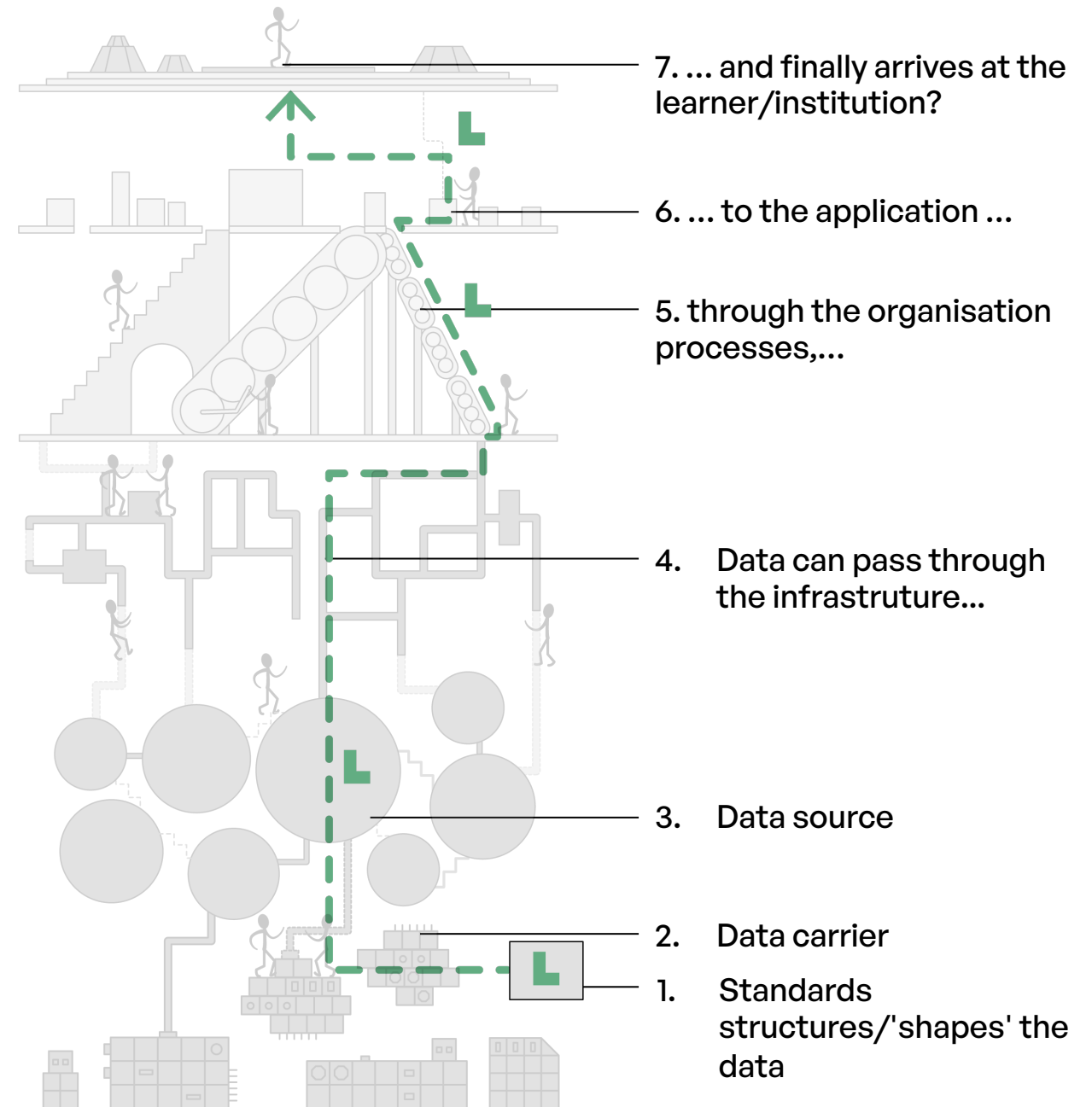

# Variations of standards

An 'Organisation & Processes' standard  
For example [...]

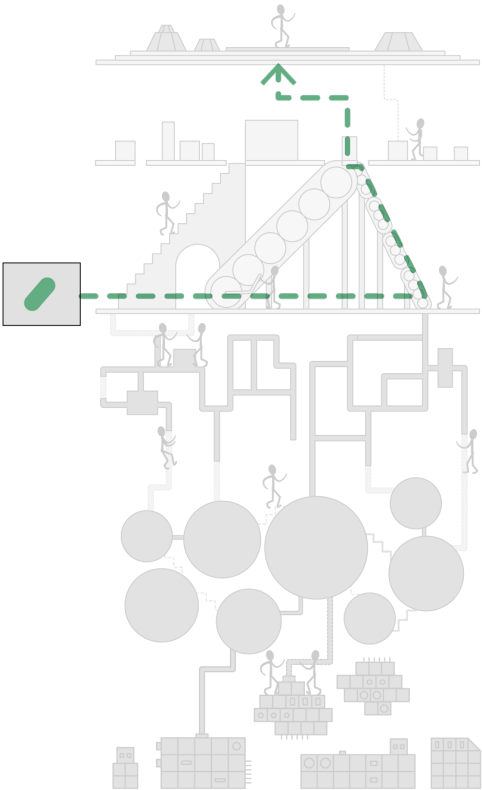

An 'Organisation & Processes' standard  
For example [...]

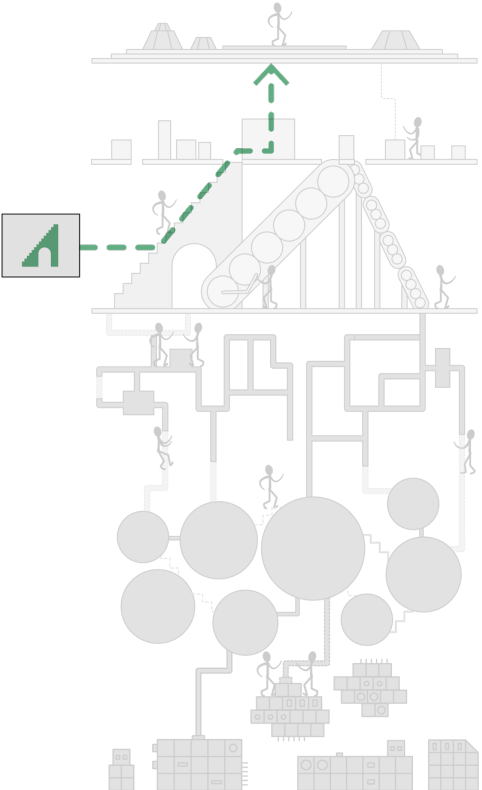

An 'Organisation & Processes' standard  
For example [...]

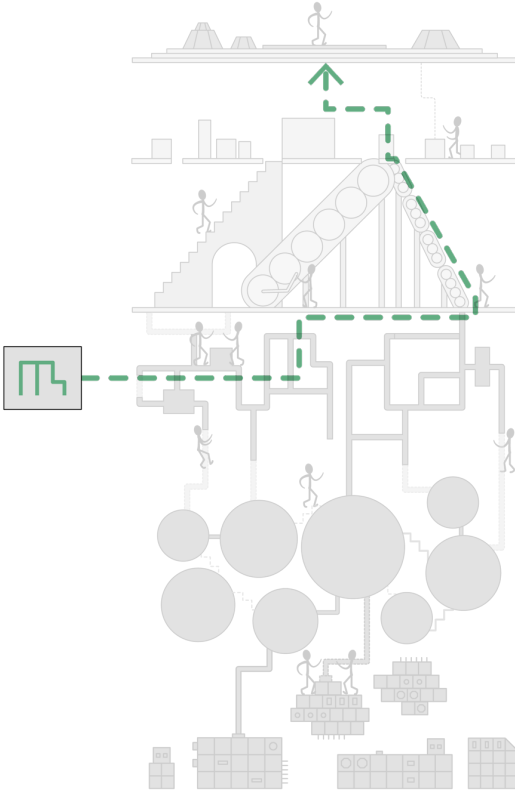

A 'Technology' standard  
For example [...]

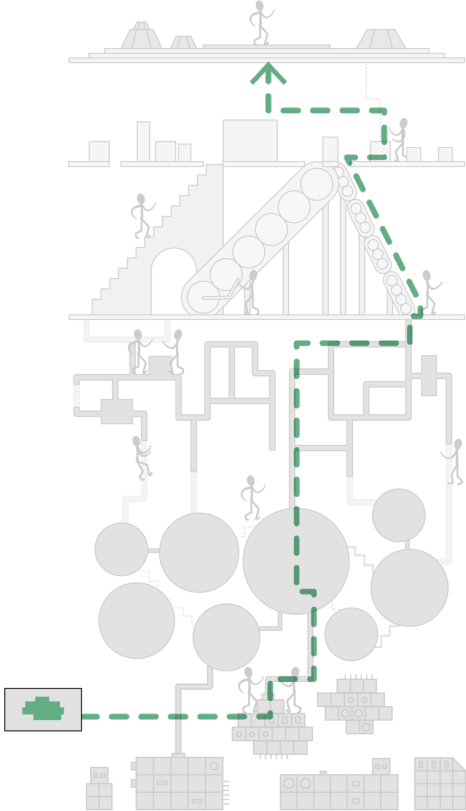

***You and your colleagues  
look at this ecosystem  
from different  
perspectives..***





***A learner will focus on the frustrating experience of trying to find the right course to take during their exchange period***

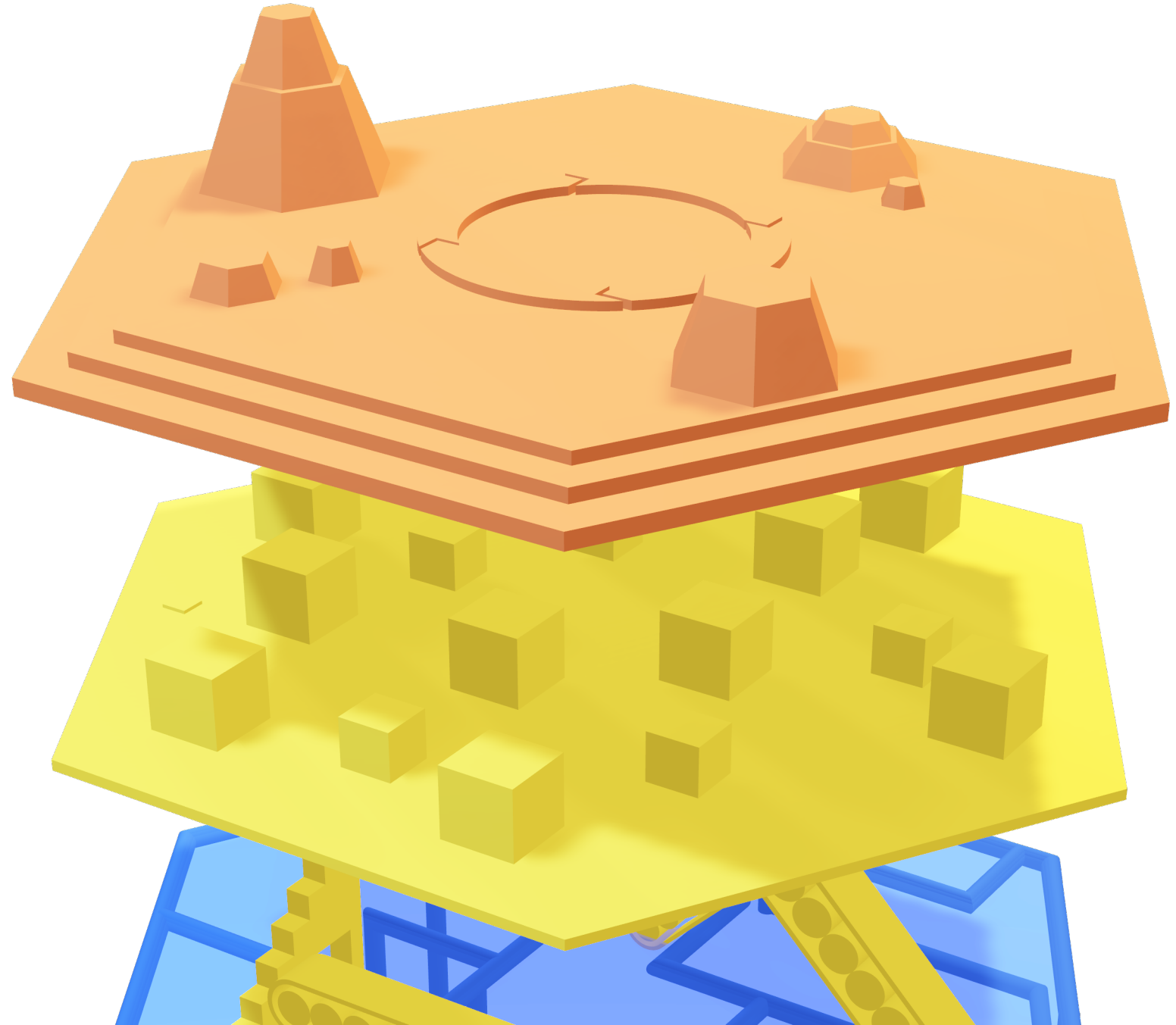

***While a CIO will  
zoom out and look  
at the bigger  
picture, taking  
into account the  
budget and  
strategic  
priorities***

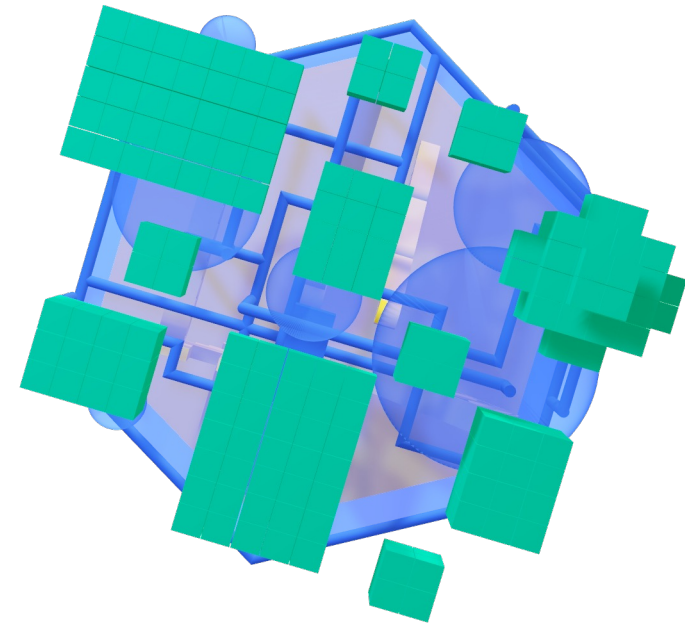

***The Erasmus+  
coordinator will  
focus on the  
Learning  
Agreement and  
Grant process***

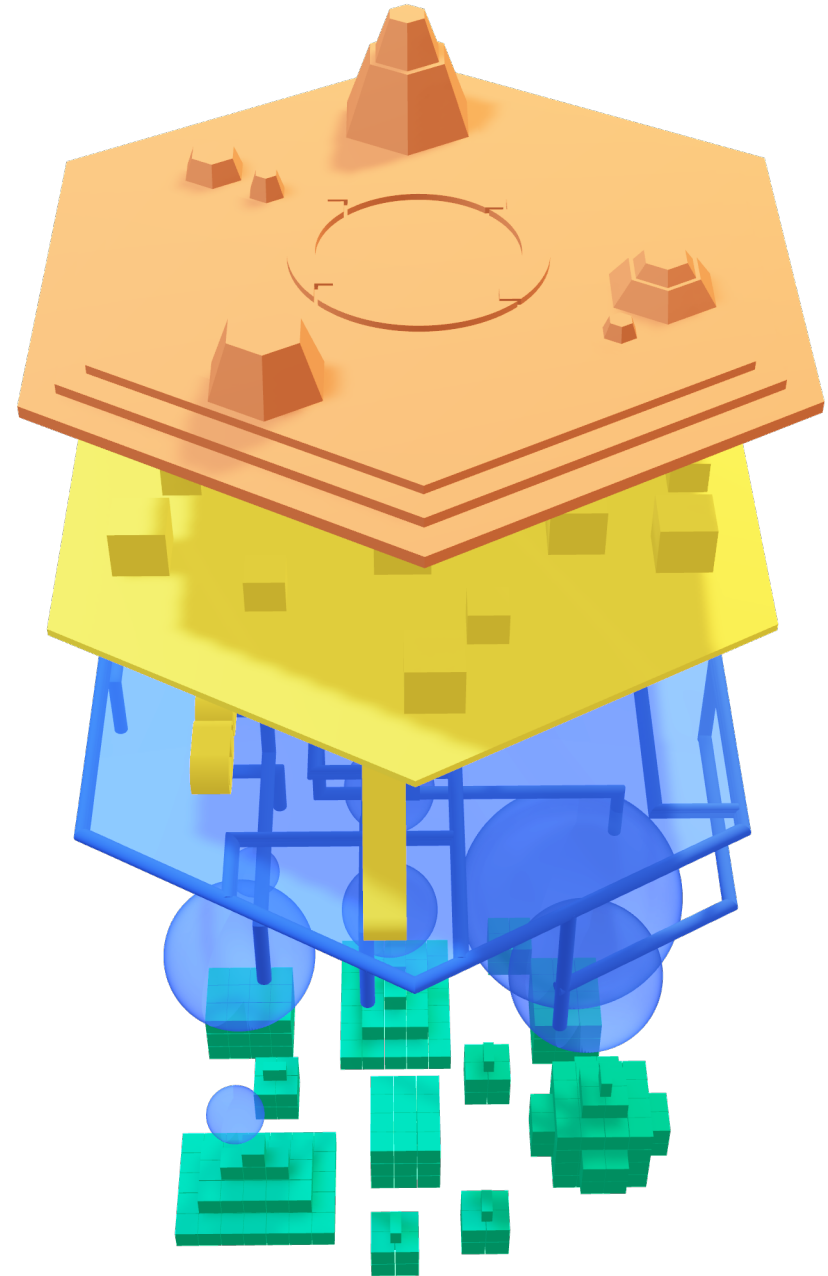

***The Identity Management colleague will look more closely into access management***

***Integration architects will work on the service bus/data brokers***

***Database managers will look at how the data is structured***

***The Enterprise architect will examine the coherence between the different layers and their relationship to strategic objectives***



***Which  
viewpoint are  
you looking  
from?***

***And can you  
still see the  
learner from  
there?***



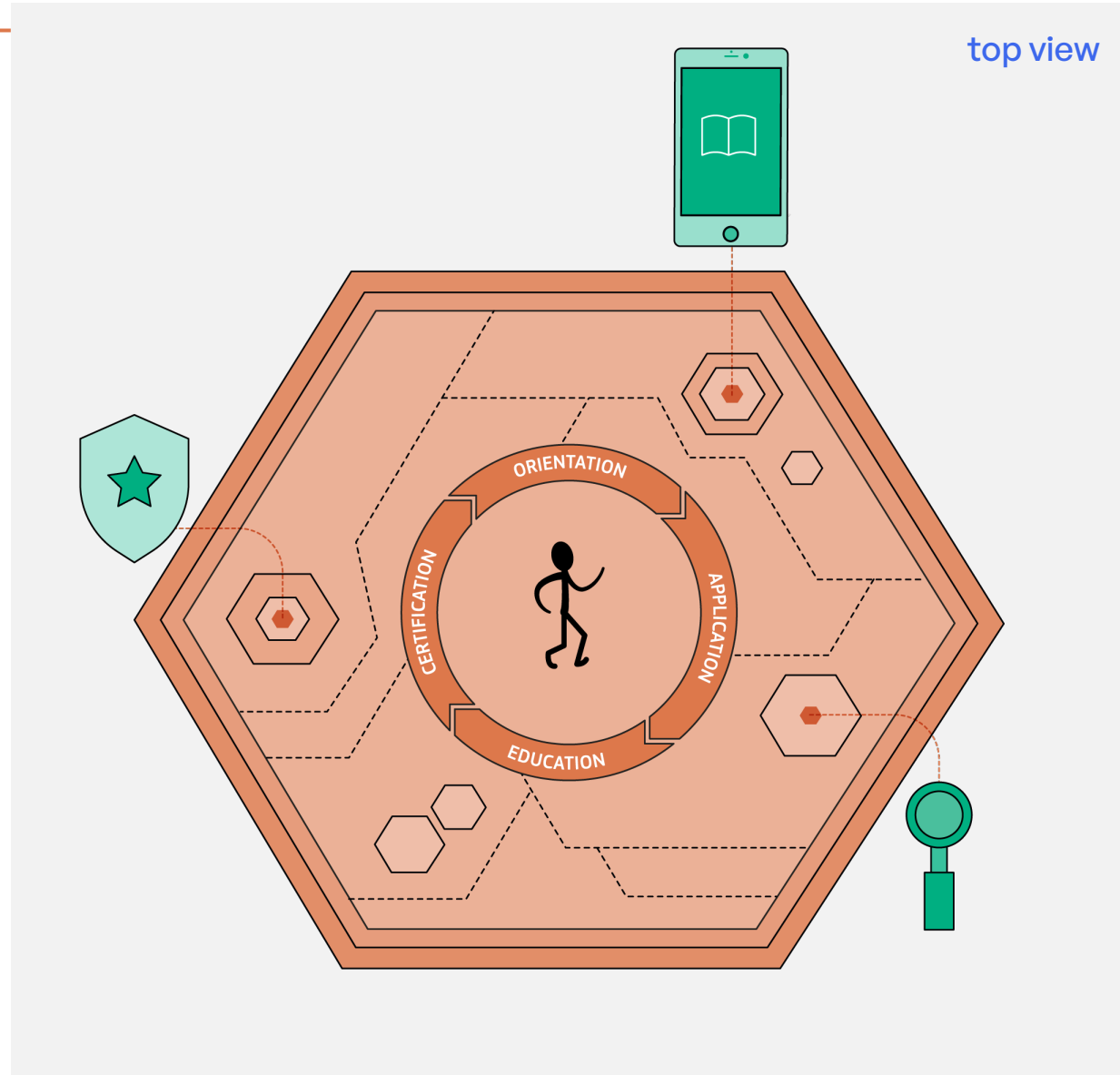
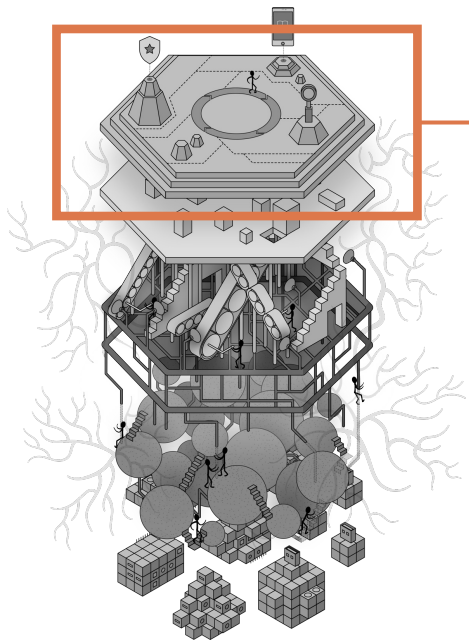

## What challenge does the user face?

*A learner wants to review courses offered by multiple programs.*

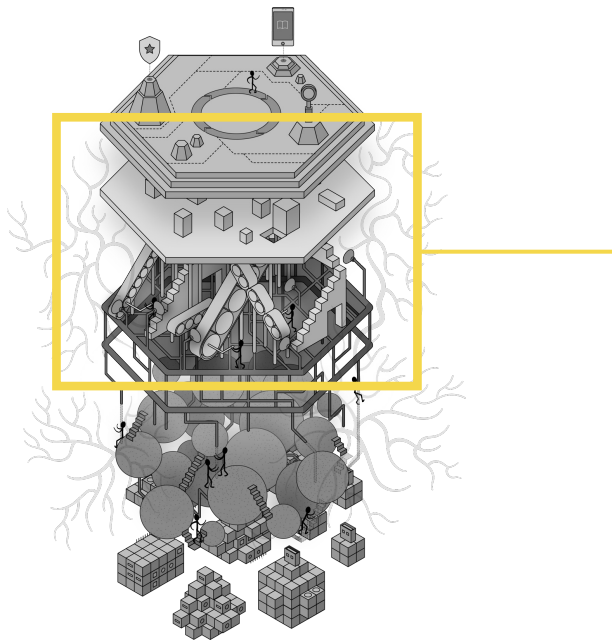

3d view

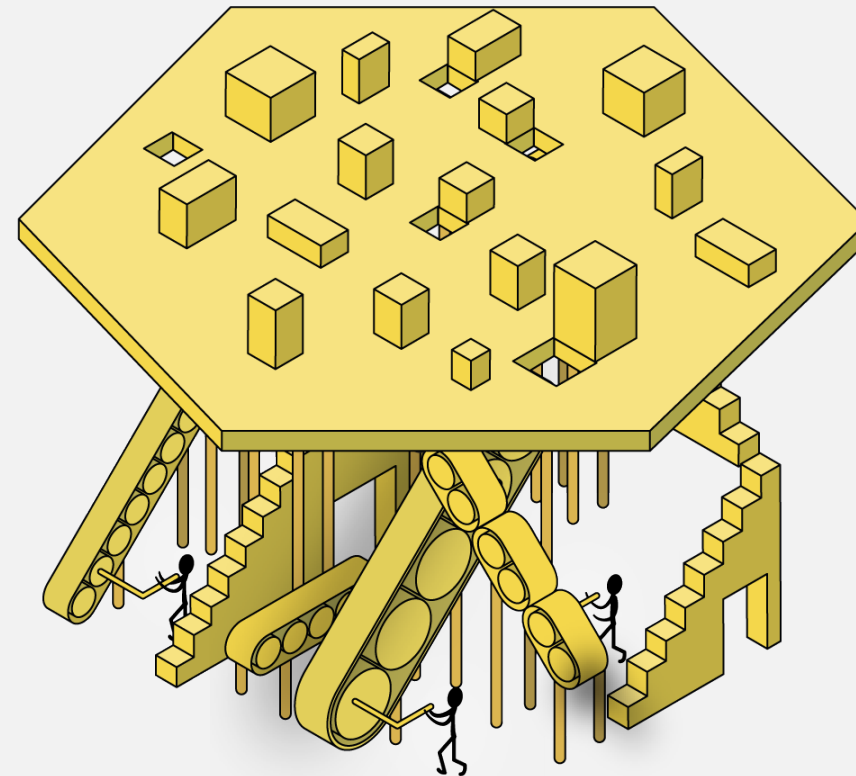

## What processes are involved on organisation level?

*At the institution's top level, agreements need to be made regarding necessary accreditation, fit in mutual curricula and costing.*

*Educational services liaise with partners to determine which information can be obtained, and what types of applications are in use.*

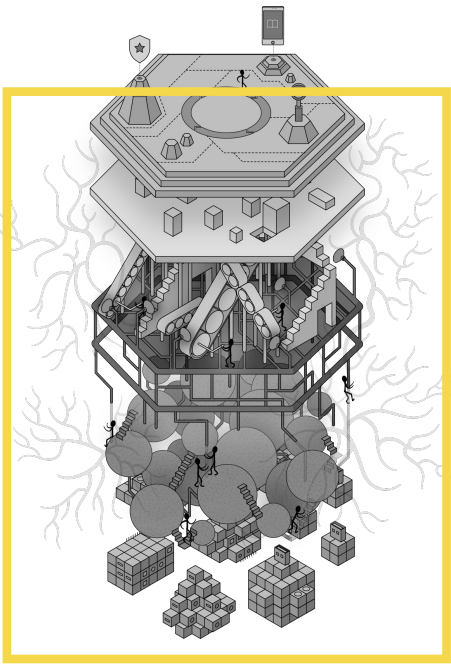

## What policy and legislation is involved?

*GDPR is European legislation that has a global impact. It is translated into national legislation and fuels the local privacy policy of an institution.*



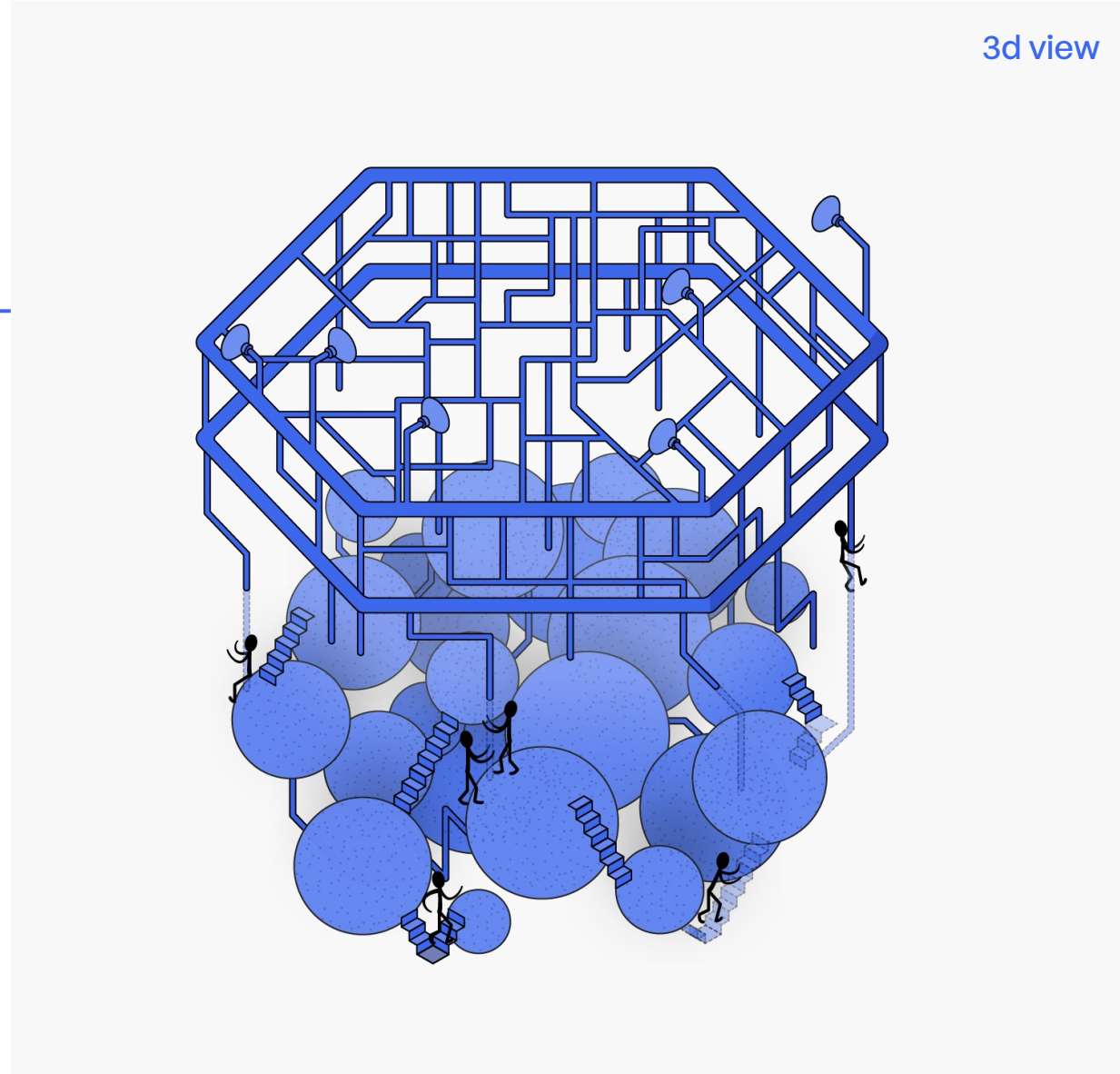
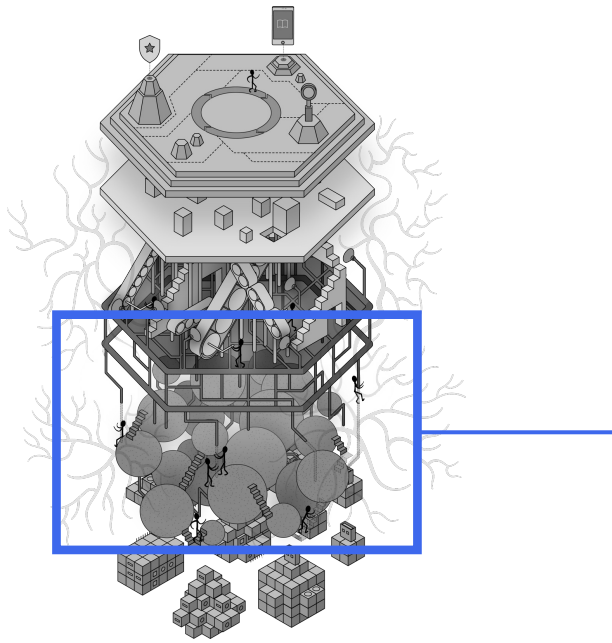

## Which applications and information are involved?

*Integration architects investigate how the different applications can work together and how information can be obtained through standardised APIs.*

*The system administrator indicates that the information is in the wrong format and therefore cannot be exchanged with other applications.*

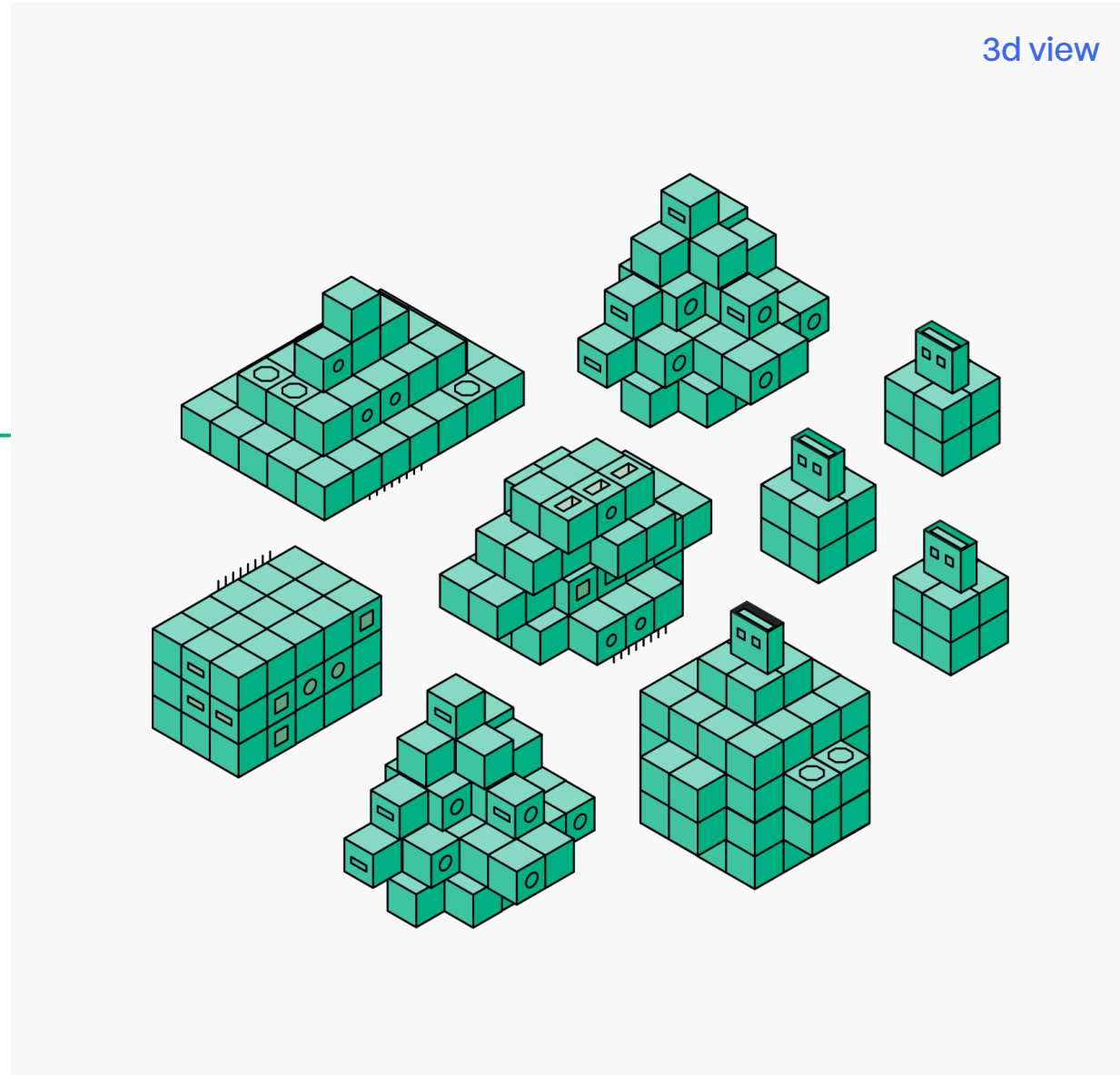
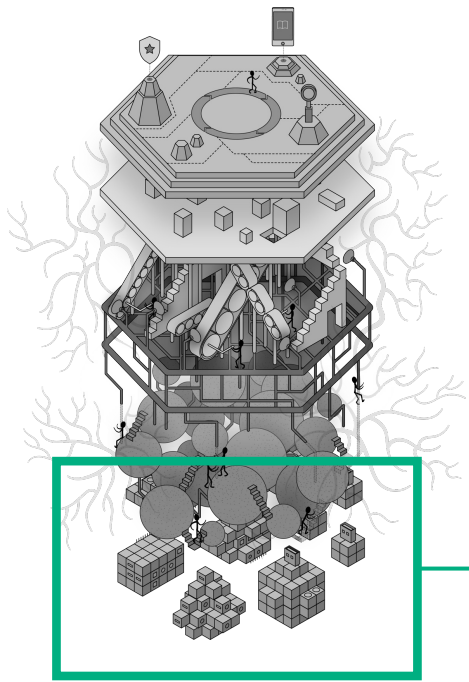

## Technology

*Together, they decide to implement a common data standard for the course information.*

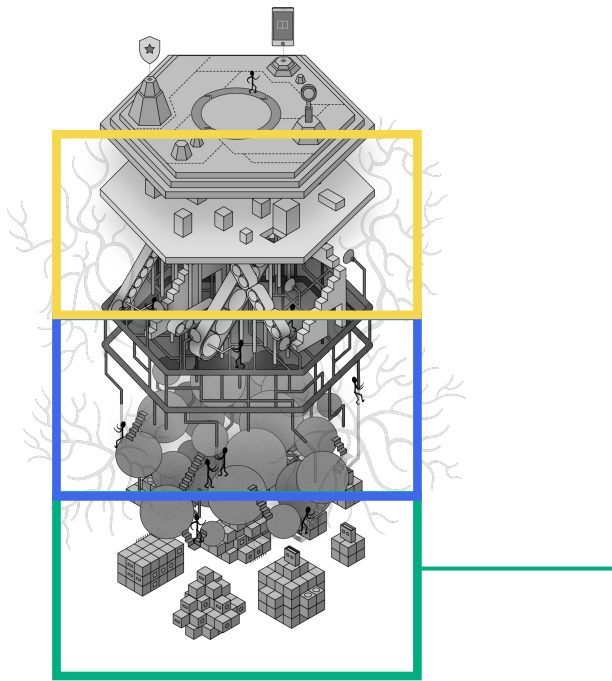

**Is there a standard we could use?**

*Together, they decide to implement a common data standard for the course information.*

**Now it's your turn!**



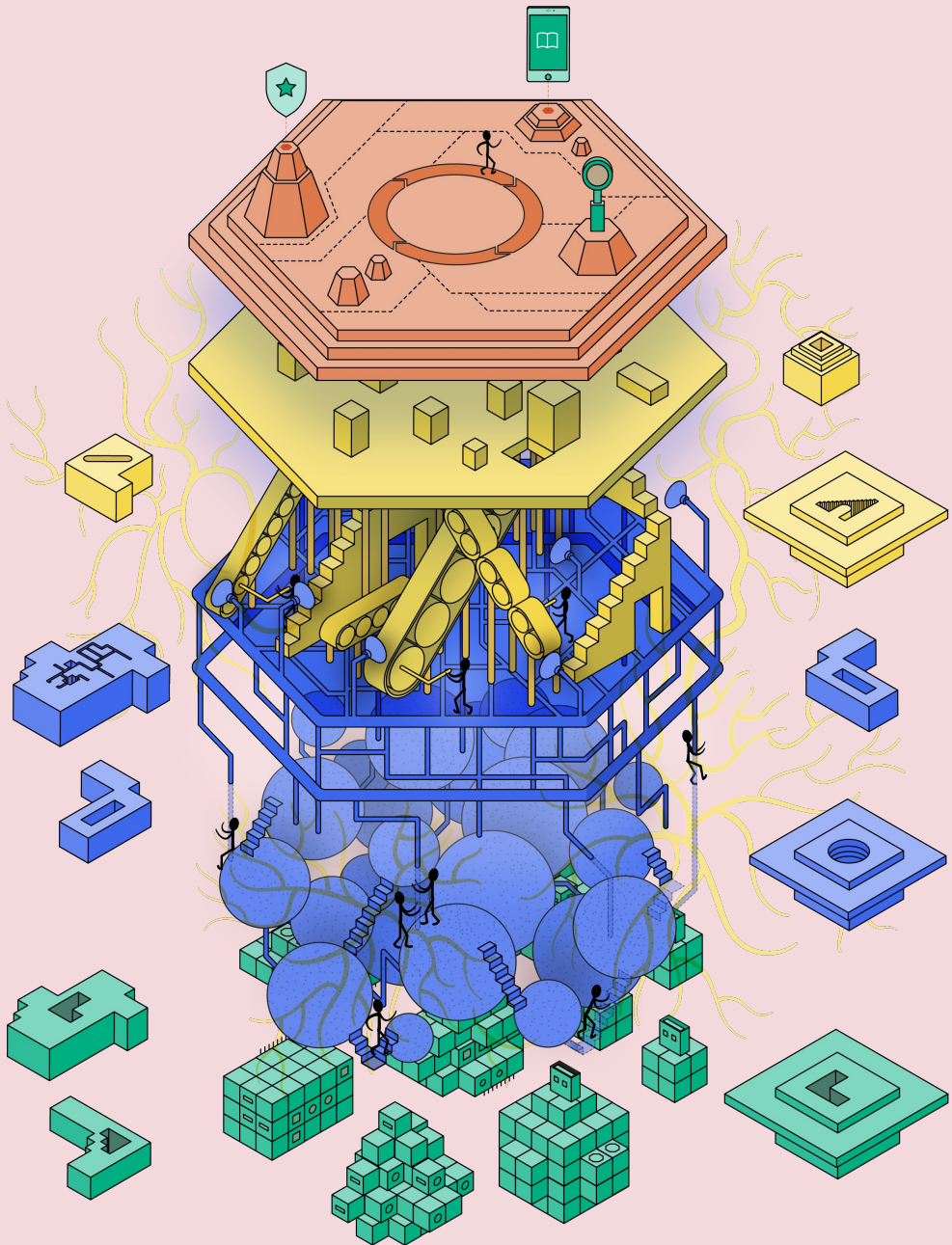

# Thank you!



[Interopvisual.eu](https://interopvisual.eu)

For questions or more information:  
[interoperability@surf.nl](mailto:interoperability@surf.nl)

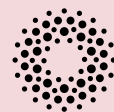

**Npuls**

**SURF**